



APE182T-3-4

GENERAL PURPOSE ELECTRIC MOTOR

NEMA PREMIUM EFFICIENCY

TOTALLY ENCLOSED FAN COOLED

INVERTER DUTY 10:1 CT; 20:1 VT - NEMA MG1 PART 31

Factory Certified for T2B Class I, Division II, Groups A,B,C & D and Class II, Division II, Groups F & G

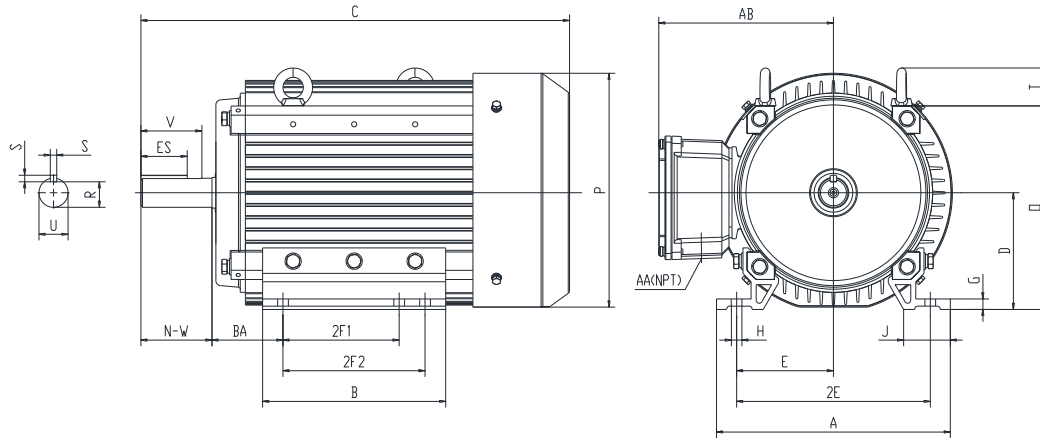

DIMENSIONS

HP	RPM	Frame	MOUNTING														
			A	B	C	D	G	H	J	E	2E	2F1	2F2	O	P	T	BA
3	1800	182T	9.5	7.1	15.6	4.5	0.4	0.41	1.81	3.75	7.5	4.5	5.5	7.85	9.2	1.54	2.75

Shaft Extension, Key Set						Conduit Box		Bearings		Mount
U	V	R	S	ES	N-W	AA	AB	DE	ODE	
1.125	2.5	0.986	0.25	1.78	2.75	0.75	7.5	6206-ZZ	6206-ZZ	F1

BEARING LUBRICATION: The bearings come lubricated with Mobil Polyrex EM Polyurea Grease.



Electrical Helper.org

For All Your Electric Needs Since 1928

411 N Platte Ave. York, NE. 68467

**AC-DC MOTORS :: SALES & SERVICE
REWINDING :: CUSTOM CONTROL PANEL**

Kelly MacMillan
Office Ph: 888-226-4917
Fax: 888-226-4917
Cell: 402-679-1579
E-Mail: kelly@electricalhelper.com





APE182T-3-4

GENERAL PURPOSE ELECTRIC MOTOR

NEMA PREMIUM EFFICIENCY

TOTALLY ENCLOSED FAN COOLED

INVERTER DUTY 10:1 CT; 20:1 VT - NEMA MG1 PART 31

Factory Certified for T2B Class I, Division II, Groups A,B,C & D and Class II, Division II, Groups F & G

PERFORMANCE DATA

HP	RPM	Frame	Voltage	Frequency (Hz)	Full Load S.F.	Insulation Class	NEMA Design	Slip (%)	NEMA Code	Enclosure Type	IP Rating	Max. Ambient
3	1760	182T	208-230/460	60	1.15	F	B	2.2	K	TEFC	55	40 °C

Amps (460V)		Efficiency (%)			Power Factor			Torque (ft-lb)			DE Bearing	ODE Bearing	Connection	Weight (lbs.)
FLA	LRA	100%	75%	50%	100%	75%	50%	FLT	LRT %	BDT %				
3.8	32	89.5	89.1	87.5	0.77	0.70	0.58	9	200	300	6206-ZZ	6206-ZZ	9 Lead 2Y/Y	68

NAME PLATE

		AC INDUCTION MOTOR INVERTER DUTY 20:1 VT; 10:1 CT								CONNECTION DIAGRAMS				
CAT NO.		APE182T-3-4				FRAME		182T		PHASE		3		
HZ	60	S.F.	1.15	HZ	50	S.F.	1.0	ENCL	TEFC	IP	55			
HP	3	RPM	1760	HP	3	RPM	1450	DUTY CONT	DES		B			
VOLTS		208-230/460				VOLTS		190/380		AMB	40 °C		INS	F
AMPS		8.2-7.6/3.8		AMPS		9.8/4.9		DE BRG		6206-ZZ				
CODE		K	P.F.	0.77	CODE		H	P.F.	0.80	ODE BRG		6206-ZZ		
EFF		89.5	MIN	87.5	EFF		87.0	MIN	85.0	LUB: Mobil Polyrex EM				
MOTOR WEIGHT		68		LBS	CONNECTION			9 Lead 2Y/Y		SER NO				
General purpose use on industrial machinery installed in damp, dusty or dirty environments. Hernando, Mississippi										CC082A E310089				
												208-230V 		
												460V 		

APPLICATIONS:

General purpose use on pumps, fans, blowers, compressors, conveyors, material handling and other industrial machinery installed in damp, dusty or dirty environments.



Electrical Helper.org

For All Your Electric Needs Since 1928

411 N Platte Ave. York, NE. 68467

**AC-DC MOTORS :: SALES & SERVICE
REWINDING :: CUSTOM CONTROL PANEL**

Kelly MacMillan

Office Ph: 888-226-4917

Fax: 888-226-4917

Cell: 402-679-1579

E-Mail: kelly@electricalhelper.com

