



PE284T-15-6

GENERAL PURPOSE ELECTRIC MOTOR
NEMA PREMIUM EFFICIENCY
TOTALLY ENCLOSED FAN COOLED

INVERTER DUTY 10:1 CT; 20:1 VT - NEMA MG1 PART 31

Factory Certified for T2B Class I, Division II, Groups A,B,C & D and Class II, Division II, Groups F & G

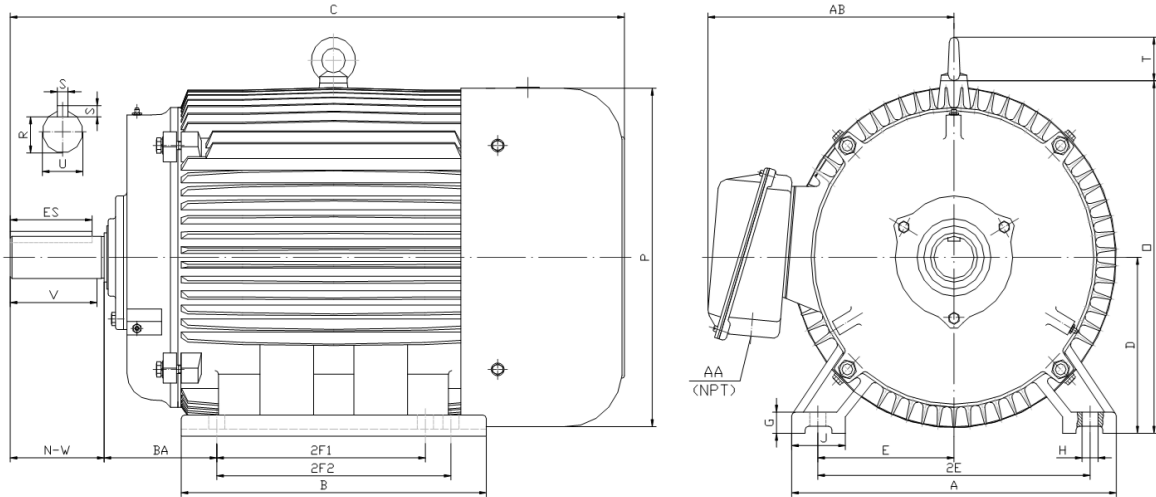

DIMENSIONS

HP	RPM	Frame	MOUNTING														
			A	B	C	D	G	H	J	E	2E	2F1	2F2	O	P	T	BA
15	1200	284T	14.00	13.20	26.60	7.00	0.85	0.53	2.75	5.50	11.00	9.50	0.00	14.50	14.00	2.20	4.75

Shaft Extension, Key Set						Conduit Box		Bearings		Mount
U	V	R	S	ES	N-W	AA	AB	DE	ODE	
1.875	4.38	1.591	0.500	3.28	4.62	1.50	11.30	6311	6311	F1

BEARING LUBRICATION: The bearings come lubricated with Mobil Polyrex EM Polyurea Grease. It is recommended that you add some additional lubrication when the motor is installed.

Three options (brands) for suitable lubrication include, but are not limited to, the following:

- 1.) Mobil Polyrex EM
- 2.) Citco Polyurea MP
- 3.) Conoco Phillips Polytac EP

ISO9001
CERTIFIED



NEMA
Premium



ElectricalHelper.org

For All Your Electric Needs Since 1928
411 N Platte Ave. York, NE. 68467

AC-DC MOTORS :: SALES & SERVICE
REWINDING :: CUSTOM CONTROL PANEL

Kelly MacMillan

Office PH: 888.226.4917 Ext. 102

Fax: 888.226.4917

Cell: 402.679.1579

E-Mail: kelly@electricalhelper.com



PE284T-15-6

GENERAL PURPOSE ELECTRIC MOTOR

NEMA PREMIUM EFFICIENCY

TOTALLY ENCLOSED FAN COOLED

INVERTER DUTY 10:1 CT; 20:1 VT - NEMA MG1 PART 31

Factory Certified for T2B Class I, Division II, Groups A,B,C & D and Class II, Division II, Groups F & G

PERFORMANCE DATA

HP	RPM	Frame	Voltage	Frequency (Hz)	Full Load S.F.	Insulation Class	NEMA Design	Slip (%)	NEMA Code	Enclosure Type	IP Rating	Max. Ambient
15	1180	284T	208-230/460	60	1.15	F	B	1.7	G	TEFC	55	40° C

Amps (460V)		Efficiency (%)				Power Factor			Torque (ft-lb)			DE Bearing	ODE Bearing	Connection	Weight (lbs.)
FLA	LRA	100%	75%	50%	Min.	100%	75%	50%	FLT	LRT %	BDT %	6311	6311	12 Lead 2Δ/Δ	315
19.0	116	91.7	91.7	91.4	90.2	0.770	0.720	0.600	67.1	160	240				

NAME PLATE

										CONNECTION DIAGRAMS 208-230V													
INVERTER DUTY 20:1 VT; 10:1 CT																							
CAT NO:		PE284T-15-6				FRAME		284T		PHASE		3											
HZ		60		S.F.		1.15		HZ		50		S.F.		1.0		ENCL		TEFC		IP		55	
HP		15		RPM		1180		HP		15		RPM		965		DUTY		CONT		DES		B	
VOLTS		208-230/460				VOLTS		190/380		AMB		40° C		INS		F							
FLA		41 - 38 / 19				FLA		46/23		DE BEARING				6311									
CODE		G		P.F.		0.77		CODE		F		P.F.		0.86		ODE BEARING		6311					
EFF		91.7		MIN		90.2		EFF		89.7		MIN		88.2		LUB: Mobil Polyrex EM							
MOTOR WEIGHT		315		LBS		CONNECTION		12 Lead 2Δ/Δ		SER NO													
General purpose use on industrial machinery installed in damp, dusty or dirty environments.																CC 082A							
												460V 											

APPLICATIONS:

General purpose use on pumps, fans, blowers, compressors, conveyors, material handling and other industrial machinery installed in damp, dusty or dirty environments.



ElectricalHelper.org

For All Your Electric Needs Since 1928
411 N Platte Ave. York, NE. 68467

AC-DC MOTORS :: SALES & SERVICE
REWINDING :: CUSTOM CONTROL PANEL

Kelly MacMillan

Office PH: 888.226.4917 Ext. 102

Fax: 888.226.4917

Cell: 402.679.1579

E-Mail: kelly@electricalhelper.com