

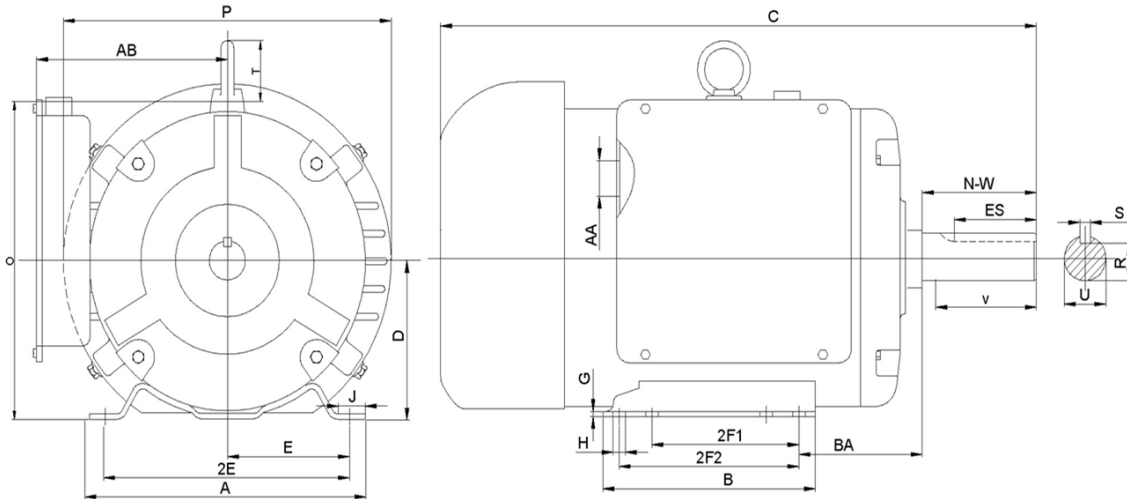

**F182T3S4C-MO**

FARM DUTY ELECTRIC MOTOR  
 HIGH STARTING TORQUE - MANUAL OVERLOAD  
 SINGLE PHASE - CAPACITOR START / CAPACITOR RUN  
 ROLLED STEEL CONSTRUCTION  
 TOTALLY ENCLOSED FAN COOLED



**DIMENSIONS**

HP	RPM	Frame	MOUNTING														
			A	B	C	D	G	H	J	E	2E	2F1	2F2	O	P	T	BA
3	1800	182T	11	9.4	20.4	5.25	0.7	0.41	2.4	4.25	8.5	4.5	5.5	11.2	11.6	1.9	3.5

Shaft Extension, Key Set						Conduit Box		Bearings		Mount
U	V	R	S	ES	N-W	AA	AB	DE	ODE	
1.125	3.12	1.201	0.312	2.41	3.38	1	9	6206-2RZC3	6205-2RZC3	F1

**BEARING LUBRICATION:** The bearings come lubricated with Mobil Polyrex EM Polyurea Grease.



**ElectricalHelper.org**

For All Your Electric Needs Since 1928  
 411 N Platte Ave. York, NE. 68467

**AC-DC MOTORS :: SALES & SERVICE**  
**REWINDING :: CUSTOM CONTROL PANEL**

**Kelly MacMillan**  
 Office PH: 888.226.4917 Ext. 102  
 Fax: 888.226.4917  
 Cell: 402.679.1579  
 E-Mail: [kelly@electricalhelper.com](mailto:kelly@electricalhelper.com)



# F182T3S4C-MO

**FARM DUTY ELECTRIC MOTOR**  
**HIGH STARTING TORQUE - MANUAL OVERLOAD**  
**SINGLE PHASE - CAPACITOR START / CAPACITOR RUN**  
**ROLLED STEEL CONSTRUCTION**

## PERFORMANCE DATA

HP	RPM	Frame	Voltage	Frequency (Hz)	Full Load S.F.	Insulation Class	NEMA Design	Slip (%)	NEMA Code	Enclosure Type	IP Rating	Max. Ambient
3	1735	182T	208-230/460V	60	1.15	F	L	3.6	H	TEFC	IP44	40°C

Amps (460V)		Efficiency (%)			Power Factor			Torque (ft-lb)			DE Bearing	ODE Bearing	Connection	Weight (lbs.)
FLA	LRA	100%	75%	50%	100%	75%	50%	FLT	LRT %	BDT %				
6.35	43.3	81.5	79	74.6	0.94	0.92	0.89	12.27	276	240	6206-2RZC3	6205-2RZC3	5 Lead/P1,P2	88

NAME PLATE					
<b>North American Electric, Inc.</b>			<b>FARM DUTY</b> HIGH STARTING TORQUE MANUAL OVERLOAD PROTECTION TOTALLY ENCLOSED FAN COOLED		
MODEL		HP	3	RPM	1735
F182T3S4C-MO		ENCL	TEFC	HZ	60
VOLT	208-230/460V	AMPS	14.5-12.55/6.35	S.F.	1.15
S.F. AMPS	16.4-14.8/7.4	CLASS	F	CODE	H
DE BEARING	6206-2RZC3				
ODE BEARING	6205-2RZC3				
MAX AMB.	40°C	RATING	CONT		
SER					
General purpose use on equipment and farm duty machinery requiring high starting torques.					

### APPLICATIONS:

General purpose use on pumps, fans, conveyors, poultry equipment, air compressors and other farm duty machinery requiring high starting torques.



**ElectricalHelper.org**

For All Your Electric Needs Since 1928  
 411 N Platte Ave. York, NE. 68467

**AC-DC MOTORS :: SALES & SERVICE**  
**REWINDING :: CUSTOM CONTROL PANEL**

**Kelly MacMillan**  
 Office PH: 888.226.4917 Ext. 102  
 Fax: 888.226.4917  
 Cell: 402.679.1579  
 E-Mail: [kelly@electricalhelper.com](mailto:kelly@electricalhelper.com)

