

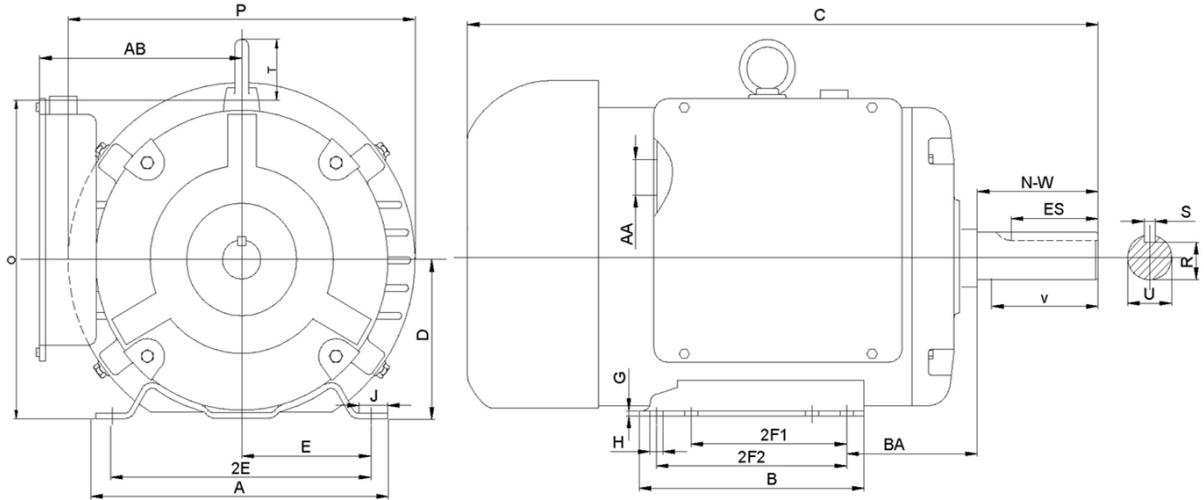

F184T5S4C-MO

FARM DUTY ELECTRIC MOTOR
 HIGH STARTING TORQUE - MANUAL OVERLOAD
 SINGLE PHASE - CAPACITOR START / CAPACITOR RUN
 ROLLED STEEL CONSTRUCTION
 TOTALLY ENCLOSED FAN COOLED



DIMENSIONS

HP	RPM	Frame	MOUNTING														
			A	B	C	D	G	H	J	E	2E	2F1	2F2	O	P	T	BA
5	1800	184T	9.5	8.3	17.1	4.5	0.6	0.41	2	3.75	7.5	4.5	5.5	9.1	8.7	1.6	2.75

Shaft Extension, Key Set						Conduit Box		Bearings		Mount
U	V	R	S	ES	N-W	AA	AB	DE	ODE	
1.125	2.5	0.986	0.25	1.78	2.75	0.75	7.5	6206-2RZC3	6205-2RZC3	F1

BEARING LUBRICATION: The bearings come lubricated with Mobil Polyrex EM Polyurea Grease.



ElectricalHelper.org

For All Your Electric Needs Since 1928
 411 N Platte Ave. York, NE. 68467

AC-DC MOTORS :: SALES & SERVICE
REWINDING :: CUSTOM CONTROL PANEL

Kelly MacMillan
 Office PH: 888.226.4917 Ext. 102
 Fax: 888.226.4917
 Cell: 402.679.1579
 E-Mail: kelly@electricalhelper.com



F184T5S4C-MO

**FARM DUTY ELECTRIC MOTOR
HIGH STARTING TORQUE - MANUAL OVERLOAD
SINGLE PHASE - CAPACITOR START / CAPACITOR RUN
ROLLED STEEL CONSTRUCTION**

PERFORMANCE DATA

HP	RPM	Frame	Voltage	Frequency (Hz)	Full Load S.F.	Insulation Class	NEMA Design	Slip (%)	NEMA Code	Enclosure Type	IP Rating	Max. Ambient
5	1735	184T	208-230/460V	60	1.15	F	L	3.6	G	TEFC	IP44	40°C

Amps (460V)		Efficiency (%)			Power Factor			Torque (ft-lb)			DE Bearing	ODE Bearing	Connection	Weight (lbs.)
FLA	LRA	100%	75%	50%	100%	75%	50%	FLT	LRT %	BDT %	6206-2RZC3	6205-2RZC3	5 Lead/P1,P2	100
10.3	67.0	83.3	81	78	0.95	0.93	0.9	20.53	243	220				

NAME PLATE							
			FARM DUTY HIGH STARTING TORQUE MANUAL OVERLOAD PROTECTION TOTALLY ENCLOSED FAN COOLED				
SINGLE PHASE ELECTRIC MOTOR							
MODEL	HP	5	RPM	1735	FRAME	184T	
F184T5S4C-MO	ENCL	TEFC	HZ	60	PHASE	1	
VOLT	208-230/460V	AMPS	23.4-20.3/10.3	S.F.	1.15	DESIGN	L
S.F. AMPS	26-23.8/11.9	CLASS	F	CODE	G	LBS	100
DE BEARING		6206-2RZC3					
ODE BEARING		6205-2RZC3					
MAX AMB.	40°C	RATING	CONT				
SER							
General purpose use on equipment and farm duty machinery requiring high starting torques.							

APPLICATIONS:

General purpose use on pumps, fans, conveyors, poultry equipment, air compressors and other farm duty machinery requiring high starting torques.



ElectricalHelper.org

For All Your Electric Needs Since 1928
411 N Platte Ave. York, NE. 68467

AC-DC MOTORS :: SALES & SERVICE
REWINDING :: CUSTOM CONTROL PANEL

Kelly MacMillan
Office PH: 888.226.4917 Ext. 102
Fax: 888.226.4917
Cell: 402.679.1579
E-Mail: kelly@electricalhelper.com