

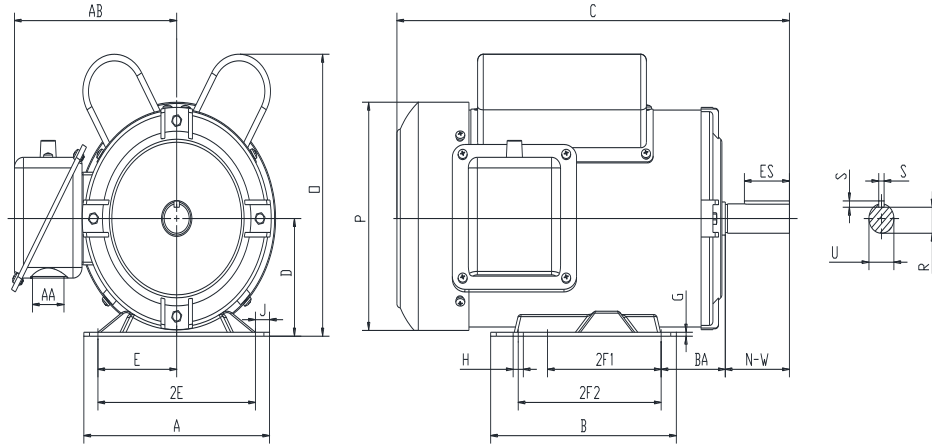

F145T1.5S4C-MO

**FARM DUTY ELECTRIC MOTOR
 HIGH STARTING TORQUE - MANUAL OVERLOAD
 SINGLE PHASE - CAPACITOR START / CAPACITOR RUN
 ROLLED STEEL CONSTRUCTION
 TOTALLY ENCLOSED FAN COOLED**



DIMENSIONS

HP	RPM	Frame	MOUNTING														
			A	B	C	D	G	H	J	E	2E	2F1	2F2	O	P	T	BA
1.5	1800	145T	6.5	6.5	12.6	3.5	0.12	0.34	0.5	2.75	5.5	4	5	8.5	6.8	NA	2.25

Shaft Extension, Key Set						Conduit Box		Bearings		Mount
U	V	R	S	ES	N-W	AA	AB	DE	ODE	
0.875	NA	0.771	0.188	1.41	2.25	1.1	6	6205-2RZC3	6203-2RZC3	F1

BEARING LUBRICATION: The bearings come lubricated with Mobil Polyrex EM Polyurea Grease.



Electrical Helper.org

For All Your Electric Needs Since 1928
 411 N Platte Ave. York, NE. 68467

**AC-DC MOTORS :: SALES & SERVICE
 REWINDING :: CUSTOM CONTROL PANEL**

Kelly MacMillan
 Office Ph: 888-226-4917
 Fax: 888-226-4917
 Cell: 402-679-1579
 E-Mail: kelly@electricalhelper.com





F145T1.5S4C-MO





FARM DUTY ELECTRIC MOTOR
HIGH STARTING TORQUE - MANUAL OVERLOAD
SINGLE PHASE - CAPACITOR START / CAPACITOR RUN
ROLLED STEEL CONSTRUCTION
TOTALLY ENCLOSED FAN COOLED

PERFORMANCE DATA

HP	RPM	Frame	Voltage	Frequency (Hz)	Full Load S.F.	Insulation Class	NEMA Design	Slip (%)	NEMA Code	Enclosure Type	IP Rating	Max. Ambient
1.5	1750	145T	115/208-230	60	1.15	F	L	2.8	J	TEFC	55	40 °C

Amps (230V)		Efficiency (%)			Power Factor			Torque (ft-lb)			DE Bearing	ODE Bearing	Connection	Weight (lbs.)
FLA	LRA	100%	75%	50%	100%	75%	50%	FLT	LRT %	BDT %				
6.2	45.6	81.7	78.5	71.5	0.96	0.95	0.92	4.52	280	260	6205-2RZC3	6203-2RZC3	5 Lead/P1,P2	45

NAME PLATE

 FARM DUTY SINGLE PHASE AC ELECTRIC MOTOR HIGH STARTING TORQUE MANUAL OVERLOAD PROTECTION																																							
MODEL	F145T1.5S4C-MO	HP	1.5																																				
FRAME	145T	ENCL	TEFC																																				
RPM	1750	CODE	J																																				
DESIGN	L	CLASS	F																																				
EFFICIENCY	81.7	P.F.	0.96																																				
DE BRG	6205-2RZC3	ODE BRG	6203-2RZC3																																				
VOLT	115/208-230	LBS	45																																				
AMPS	12.4/6.9-6.2	DUTY	CONT																																				
S.F.AMPS	14.26/7.94-7.13	MAX AMB	40 °C																																				
CONNECTION	5 Lead/P1,P2	SER #																																					
<table border="0"> <tr> <td colspan="2">115V LOW VOLTAGE</td> <td colspan="2">208-230V HIGH VOLTAGE</td> </tr> <tr> <td>CCW</td> <td>CW</td> <td>CCW</td> <td>CW</td> </tr> <tr> <td>P1 — L1</td> <td>P1</td> <td>P1 — L1</td> <td>P1</td> </tr> <tr> <td>P2</td> <td>P2</td> <td>P2</td> <td>P2</td> </tr> <tr> <td>T3</td> <td>T3</td> <td>T2</td> <td>T2</td> </tr> <tr> <td>T8</td> <td>T5</td> <td>T3</td> <td>T3</td> </tr> <tr> <td>T2</td> <td>T2</td> <td>T8</td> <td>T5</td> </tr> <tr> <td>T4</td> <td>T4</td> <td>T4 — L2</td> <td>T4</td> </tr> <tr> <td>T5</td> <td>T8</td> <td>T5</td> <td>T8</td> </tr> </table>				115V LOW VOLTAGE		208-230V HIGH VOLTAGE		CCW	CW	CCW	CW	P1 — L1	P1	P1 — L1	P1	P2	P2	P2	P2	T3	T3	T2	T2	T8	T5	T3	T3	T2	T2	T8	T5	T4	T4	T4 — L2	T4	T5	T8	T5	T8
115V LOW VOLTAGE		208-230V HIGH VOLTAGE																																					
CCW	CW	CCW	CW																																				
P1 — L1	P1	P1 — L1	P1																																				
P2	P2	P2	P2																																				
T3	T3	T2	T2																																				
T8	T5	T3	T3																																				
T2	T2	T8	T5																																				
T4	T4	T4 — L2	T4																																				
T5	T8	T5	T8																																				
Hernando, MS www.naemotors.com   																																							

APPLICATIONS:

General purpose use on pumps, fans, conveyors, poultry equipment, air compressors and other farm duty machinery requiring high starting torques.



Electrical Helper.org

For All Your Electric Needs Since 1928
 411 N Platte Ave. York, NE. 68467

AC-DC MOTORS :: SALES & SERVICE
REWINDING :: CUSTOM CONTROL PANEL

Kelly MacMillan
Office Ph: 888-226-4917
Fax: 888-226-4917
Cell: 402-679-1579
E-Mail: kelly@electricalhelper.com

