

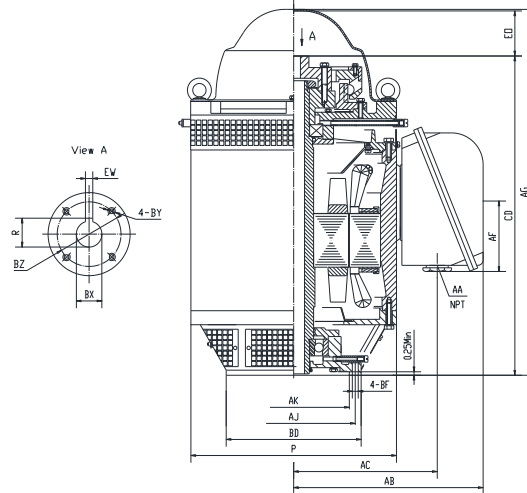

V1-20D4-W25610A

**VERTICAL HOLLOW SHAFT MOTOR
 NEMA PREMIUM EFFICIENCY
 INVERTER RATED 10:1 VT
 HIGH THRUST DESIGN
 THREE PHASE, OPEN DRIP PROOF (WP1) ENCLOSURE
 NON-REVERSE BALL TYPE RATCHET
 COUPLING INCLUDED**



DIMENSIONS

HP	RPM	Frame	MOUNTING DIMENSIONS													
			BD	AJ	AK	BF	BX	BZ	EW	R	BY	CD	E0 >	AC	AA	AF
20	1780	256TP	10	9.125	8.25	0.44	1	1.38	0.25	1.114	10-32	23.38	3.22	10.6	3	5.83

OVERALL DIMENSIONS			BEARINGS	
P	AB	AG	UPPER	LOWER
15.24	14.39	26.8	6212	7312B

COUPLING: Motor comes with a 1.0" coupling. You may select a different size coupling at no extra charge.

BEARING LUBRICATION: The bearings come lubricated with Mobil Polyrex EM Polyurea Grease.

STEADY BUSHING: Motor is designed to accept a steady bushing. The bore size is 1 inches.



Electrical Helper.org

For All Your Electric Needs Since 1928
 411 N Platte Ave. York, NE. 68467

**AC-DC MOTORS :: SALES & SERVICE
 REWINDING :: CUSTOM CONTROL PANEL**

Kelly MacMillan
 Office Ph: 888-226-4917
 Fax: 888-226-4917
 Cell: 402-679-1579
 E-Mail: kelly@electricalhelper.com





V1-20D4-W25610A







VERTICAL HOLLOW SHAFT MOTOR
NEMA PREMIUM EFFICIENCY
INVERTER RATED 10:1 VT
HIGH THRUST DESIGN
THREE PHASE, OPEN DRIP PROOF (WP1) ENCLOSURE
NON-REVERSE BALL TYPE RATCHET
COUPLING INCLUDED

PERFORMANCE DATA

HP	RPM	Frame	Voltage	Frequency (Hz)	Full Load S.F.	Insulation Class	NEMA Design	Slip (%)	NEMA Code	Enclosure Type	IP Rating	Max. Ambient	Rating CONT
20	1780	256TP	230/460	60	1.15	F	B	1.08	H	WP1	23	40° C	S1

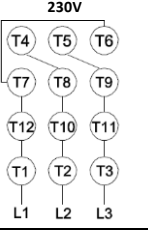
Amps (460V)		Efficiency (%)				Power Factor			Torque (ft-lb)			Down Thrust	Radial Ball Bearing	Angular Contact Bearing	Connection	Weight (lbs.)
FLA	LRA	100%	75%	50%	Min.	100%	75%	50%	FLT	LRT %	BDT %	3200	UPPER	LOWER	12 Lead 2Δ/Δ	510
23.5	174	93.0	92.8	91.6	91.7	0.86	0.82	0.72	58	235	265		6212	7312B		

NAME PLATE

 VERTICAL HOLLOW SHAFT HIGH THRUST DESIGN 						CONNECTION DIAGRAMS		
MODEL V1-20D4-W25610A						FRAME 256TP		
Hz	60	S.F.	1.15	ENCL	WP1	DESIGN	B	
HP	20	RPM	1780	INS	F	PHASE	3	
VOLTS	230/460	FLA	47/23.5	MAX.AMBIENT		40° C		
Enclosure	ODP	IP	23	RATING		CONTINUOUS		
NEMA CODE	H	P.F.	0.86	MOTOR WEIGHT		510	LBS.	
NOM EFF	93.0	MIN EFF	91.7	CONNECTION		12 Lead 2Δ/Δ		
DOWN THRUST		3200		BASE DIAMETER		10	INCHES	
UPPER BEARING		6212		LOWER BEARING		7312B		
LUBRICATION		MOBIL POLYREX EM		LUBRICATION		MOBIL POLYREX EM		
NON-REVERSE RATCHET - BALL TYPE		SERIAL NO.						
Specifically designed for use on deep well turbine pump applications. Hernando, Mississippi								CC326B
ROTATION								PART WIND START CAPABLE @ 230V
MOTOR IS SUITABLE FOR INVERTER RATED 10:1 VT								

APPLICATIONS:

Specifically designed for use on deep well turbine pump applications. The coupling is equipped with a non-reverse ratchet, which prevents motor rotation from backspin at shutdown. These motors are built to NEMA standards and have special bearing arrangements to carry heavy thrust loads.



Electrical Helper.org
 For All Your Electric Needs Since 1928
 411 N Platte Ave. York, NE. 68467

AC-DC MOTORS :: SALES & SERVICE
REWINDING :: CUSTOM CONTROL PANEL

Kelly MacMillan
 Office Ph: 888-226-4917
 Fax: 888-226-4917
 Cell: 402-679-1579
 E-Mail: kelly@electricalhelper.com

