

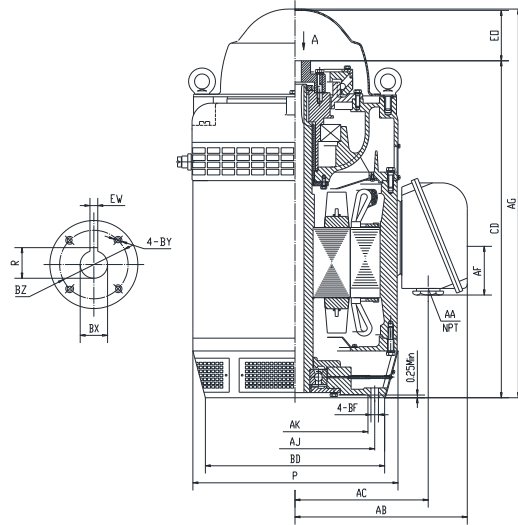

**V2-75D4-W36516B**

- VERTICAL HOLLOW SHAFT MOTOR
- NEMA PREMIUM EFFICIENCY
- INVERTER DUTY 20:1 VT
- INCLUDES INSULATED BEARING MOUNT - 40 HP AND ABOVE
- HIGH THRUST DESIGN
- THREE PHASE, OPEN DRIP PROOF (WP1) ENCLOSURE
- NON-REVERSE BALL TYPE RATCHET
- COUPLING INCLUDED



**DIMENSIONS**

HP	RPM	Frame	MOUNTING DIMENSIONS													
			BD	AJ	AK	BF	BX	BZ	EW	R	BY	CD	E0 >	AC	AA	AF
75	1787	365TP	16.5	14.75	13.5	0.69	1-3/16	1.75	0.25	1.304	1-4/20	31.16	4.56	12.56	3	5.83

OVERALL DIMENSIONS			BEARINGS	
P	AB	AG	UPPER	LOWER
19.1	16.32	36	7224B	6314

**COUPLING:** Motor comes with a 1.188" coupling. You may select a different size coupling at no extra charge.

**BEARING LUBRICATION:** The lower bearing comes lubricated with Mobil Polyrex EM Polyurea Grease.

**OIL RESERVOIR:** Motor is shipped without oil. The oil capacity is 1.94 quarts.

**STEADY BUSHING:** Motor is designed to accept a steady bushing. The bore size is 1-3/16 inches.



**Electrical Helper.org**  
 For All Your Electric Needs Since 1928  
 411 N Platte Ave. York, NE. 68467

**AC-DC MOTORS :: SALES & SERVICE**  
**REWINDING :: CUSTOM CONTROL PANEL**

Kelly MacMillan  
 Office Ph: 888-226-4917  
 Fax: 888-226-4917  
 Cell: 402-679-1579  
 E-Mail: kelly@electricalhelper.com





**Electrical Helper.org**

For All Your Electric Needs Since 1928  
411 N Platte Ave. York, NE. 68467

**V2-75D4-W36516B**

**VERTICAL HOLLOW SHAFT MOTOR  
NEMA PREMIUM EFFICIENCY  
INVERTER DUTY 20:1 VT  
INCLUDES INSULATED BEARING MOUNT - 40 HP AND ABOVE  
HIGH THRUST DESIGN  
THREE PHASE, OPEN DRIP PROOF (WP1) ENCLOSURE  
NON-REVERSE BALL TYPE RATCHET  
COUPLING INCLUDED**

**AC-DC MOTORS :: SALES & SERVICE  
REWINDING :: CUSTOM CONTROL PANEL**

**Kelly MacMillan**  
Office Ph: 888-226-4917  
Fax: 888-226-4917  
Cell: 402-679-1579  
E-Mail: [kelly@electricalhelper.com](mailto:kelly@electricalhelper.com)



**PERFORMANCE DATA**

HP	RPM	Frame	Voltage	Frequency (Hz)	Full Load S.F.	Insulation Class	NEMA Design	Slip (%)	NEMA Code	Enclosure Type	IP Rating	Max. Ambient	Rating CONT
75	1785	365TP	230/460	60	1.15	F	B	0.79	H	WP1	23	40° C	S1

Amps (460V)		Efficiency (%)				Power Factor			Torque (ft-lb)			Down Thrust	Angular Contact Bearing	Radial Ball Bearing	Connection	Weight (lbs.)
FLA	LRA	100%	75%	50%	Min.	100%	75%	50%	FLT	LRT %	BDT %	5600	UPPER	LOWER	12 Lead 2Δ/Δ	1053
85	665	95.0	94.7	93.5	94.1	0.87	0.85	0.79	217	235	270		7224B	6314		

**NAME PLATE**

							<b>VERTICAL HOLLOW SHAFT HIGH THRUST DESIGN</b>						<b>CONNECTION DIAGRAMS</b>		
MODEL		V2-75D4-W36516B					FRAME	365TP							
Hz	60	S.F.	1.15	ENCL	WP1	DESIGN	B								
HP	75	RPM	1785	INS	F	PHASE	3								
VOLTS	230/460	FLA	170/85	MAX.AMBIENT			40° C								
Enclosure	ODP	IP	23	RATING			CONTINUOUS								
NEMA CODE	H	P.F.	0.87	MOTOR WEIGHT		1053	LBS.								
NOM EFF	95.0	MIN EFF	94.1	CONNECTION		12 Lead 2Δ/Δ									
DOWN THRUST		5600		BASE DIAMETER		16.5	INCHES								
UPPER BEARING		7224B		LOWER BEARING		6314									
OIL CAP. UPPER BEARING		1.94	QTS.	LUBRICATION		MOBIL POLYREX EM									
NON-REVERSE RATCHET - BALL TYPE				SERIAL NO.											
Specifically designed for use on deep well turbine pump applications. Hernando, Mississippi								CC326B	PART WIND START CAPABLE @ 230V						
ROTATION															

**MOTOR IS SUITABLE FOR INVERTER RATED 20:1 VT**

**APPLICATIONS:**

Specifically designed for use on deep well turbine pump applications. The coupling is equipped with a non-reverse ratchet, which prevents motor rotation from backspin at shutdown. These motors are built to NEMA standards and have special bearing arrangements to carry heavy thrust loads.